

SHEARS SPECIFICATIONS

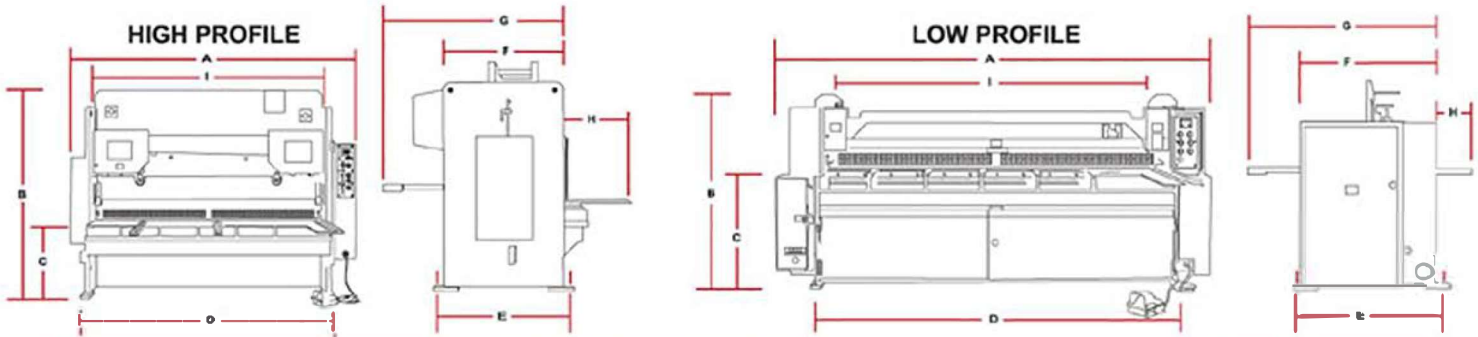

- A Overall Length
- B Overall Height
- C Table Height
- D Anchor Bolt Dimension/Length
- E Anchor Bolt Dimension/Width
- F End Plate Width
- G Machine w/Backgauge
- H Squaring Arm Length: (4' Std.)
- I Knife Length
- J Rate Angle per Rated Capacity
- K Strokes Per Minute
- L Number of Holddown Pins

	MODEL	KNIVES	H.P.*	A	B	C	D	E	F	G	H	I	J	K	L	Wts.**
1/8" OR 10 GA	2'-125	1/2x2	10	48	55	32	33	36	30	74	30	28	1/4	35	8	3,400
	4'-125	1x3	10	85	55	32	64	36	30	74	30	52	1/4	35	13	5,000
	5'-125	1/2x2	10	95	55	32	64	36	30	74	30	82	1/4	35	13	4,800
	6'-125	1x3	10	97	55	32	78	36	30	74	30	76	1/4	35	13	6,800
	8'-125	1x3	10	121	55	32	100	36	30	74	30	100	1/4	32	15	6,800
	10'-125	1x3	10	145	55	32	124	36	30	74	30	124	1/4	30	19	9,100
	12'-125	1x3	10	169	50	32	148	36	30	74	30	148	1/4	28	21	14,000
3/16"	14'-125	1x3	10	193	50	32	172	36	30	74	30	172	1/4	24	23	18,000
	16'-125	1x3	10	217	50	32	217	36	30	74	30	196	1/4	22	25	20,000
	2'-1875	1/2x2	10	48	64	32	40	36	30	74	30	28	1/4	35	8	3,500
	4'-1875	1x3	10	73	55	32	62	36	30	74	30	62	1/4	35	11	4,500
	5'-1875	1/2x2	10	85	55	32	64	36	30	74	30	52	1/4	35	13	4,800
	6'-1875	1x3	10	97	55	32	78	36	30	74	30	76	1/4	35	13	6,700
	8'-1875	1x3	10	121	55	32	100	36	30	74	30	100	1/4	32	15	7,000
1/4" LPE	10'-1875	1x3	10	145	55	32	124	36	30	74	30	124	1/4	30	19	9,100
	12'-1875	1x3	10	169	50	32	148	36	30	74	30	148	1/4	28	21	15,000
	14'-1875	1x3	10	193	50	32	172	36	30	74	30	172	1/4	24	23	19,000
	16'-1875	1x3	10	217	50	32	196	36	30	74	30	196	1/4	23	25	20,500
	4'-250 LPE	1x3	10	85	55	32	64	36	30	74	30	52	1/2	35	13	5,000
	6'-250 LPE	1 1/2x3	10	97	55	32	78	36	30	74	30	76	1/2	35	13	7,000
	1/4"	4'-250	1x4	15	64	61	32	55	50 1/2	44	76	35	52	1/4	20	13
8'-250		1x4	15	108	61	32	79	50 1/2	44	76	35	76	1/4	19	13	8,400
8'-250		1x4	15	132	61	32	103	50 1/2	44	76	35	100	1/4	17	15	9,800
10'-250		1x4	15	136	61	32	127	50 1/2	44	76	35	124	1/4	15	19	12,500
12'-250		1x4	15	180	61	32	151	50 1/2	44	76	35	148	1/4	13	21	14,000
14'-250		1x4	15	204	61	32	175	50 1/2	44	76	35	172	1/4	11	23	20,000
16'-250		1x4	15	228	61	32	199	50 1/2	44	76	35	196	1/4	10	25	22,000
3/8"	2'-375	1/2x2	15	48	64	38	40	35	34	80	10	28	1/4	12	6	4,400
	4'-375	1x4	20	75 1/2	64	32	56	55	48	80	24	52	3/8	17	11	11,000
	6'-375	1x4	20	99 1/2	64	32	80	55	48	80	24	76	3/8	17	11	15,100
	8'-375	1x4	20	123 1/2	64	32	104	55	48	80	24	100	3/8	13	14	18,500
	10'-375	1x4	20	147 1/2	64	32	128	55	48	80	24	124	3/8	11	17	21,000
	12'-375	1x4	20	171 1/2	64	32	152	55	48	80	24	148	3/8	10	20	24,000
	14'-375	1x4	20	195 1/2	64	32	176	55	48	80	24	172	3/8	9	23	27,000
1/2"	4'-500	1x4	20	75 1/2	64	32	56	55	48	80	24	52	1/2	13	11	13,800
	6'-500	1x4	20	99 1/2	64	32	80	55	48	80	24	76	1/2	13	11	17,000
	8'-500	1x4	20	123 1/2	64	32	104	55	48	80	24	100	1/2	10	14	22,500
	10'-500	1x4	20	147 1/2	64	32	128	55	48	80	24	124	1/2	9	17	28,000
	12'-500	1x4	20	171 1/2	64	32	152	55	48	80	24	148	1/2	8	20	32,000
5/8"	10'-625	1x4	30	147 1/2	64	32	128	55	48	80	24	124	1/2	9	17	28,000
	12'-625	1x4	30	171 1/2	64	32	152	55	48	80	24	148	1/2	8	20	32,000
3/4"	4'-750	1 1/8x5	40	77	97	32	58	55	48	80	32	52	5/8	11	11	15,700
	6'-750	1 1/8x5	40	101	97	32	80	55	48	80	32	76	5/8	10	11	22,000
	8'-750	1 1/8x5	40	125	97	32	104	55	48	80	32	100	5/8	8	14	27,000
	10'-750	1 1/8x5	40	149	97	32	128	55	48	80	32	124	5/8	7	17	31,000
1"	12'-750	1 1/8x5	40	173	97	32	152	55	48	80	32	148	5/8	6	20	35,000
	1'-12'	1x4	20	48	64	38	128	55	36	60	12	16	1/4	12	8	10,000

Please note:
ALL measurements and weights can vary from the figures given in this Specification Chart

All dimensions are in inches unless noted. (To convert from inches to centimeters multiply by 2.54)
 Engineering data and dimensions are subject to change without notice, due to continuing product development.
 Upon request, foundation plans will be furnished.
 1/4", 3/16", and 10 GA machines will be low profile, unless it is a gap type machine.
 * Larger motor sizes are available. To convert from horsepower to KW, multiply by 0.746.
 **ESTIMATED WEIGHTS. The weight of your machine may vary from the estimated weight listed here.
 Weights may vary according to options included.
 ***1 x 12" has separate power unit.
 * All estimated figures for 2'-125, 2'-1875 and 2'-375

HP	AMPS	
	208/230	460
5	14	7
10	28	14
15	39.6	19.3
20	52	26
25	68	34
30	80	40
40	104	52